

TEFCO ENGINEERING STANDARD ROPE SHEAVE

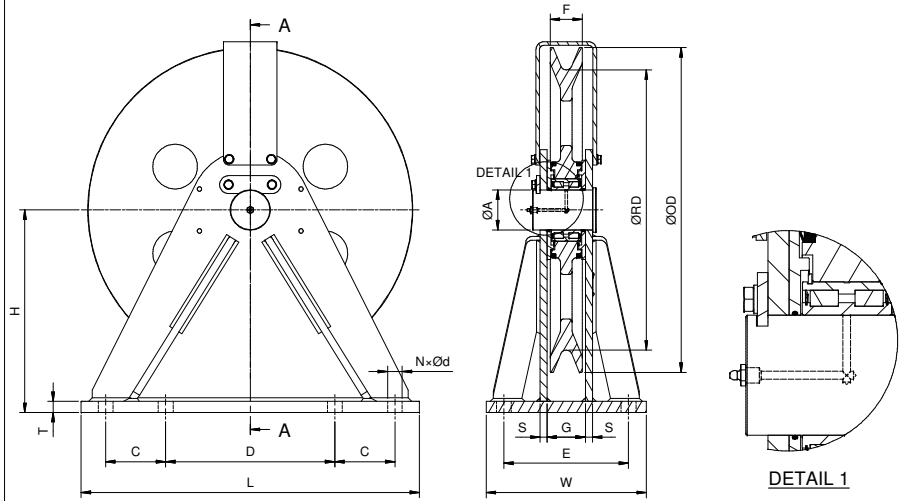

		CLASS OF MECHANISMS (AS1418)														
ROPE Ø	MAX. TENSION *	TSH200	TSH250	TSH315	TSH350	TSH400	TSH500	TSH630	TSH710	TSH800	TSH864	TSH900	TSH1000	TSH1102	TSH1500	TSH1900
10	15 kN	M5	M7	M8	-	-	-	-	-	-	-	-	-	-	-	-
12	20 kN	M3	M5	M7	M8	M8	-	-	-	-	-	-	-	-	-	-
14	30 kN	M2	M4	M6	M8	M8	-	-	-	-	-	-	-	-	-	-
16	40 kN	M1	M3	M4	M5	M7	-	-	-	-	-	-	-	-	-	-
18	50 kN	-	M2	M3	M4	M6	M7	-	-	-	-	-	-	-	-	-
20	60 kN	-	M1	M2	M3	M5	M7	-	-	-	-	-	-	-	-	-
22	75 kN	-	-	M2	M3	M4	M6	M8	-	-	-	-	-	-	-	-
24	90 kN	-	-	M1	M2	M3	M5	M7	-	-	-	-	-	-	-	-
26	105 kN	-	-	M1	M2	M4	M6	M7	-	-	-	-	-	-	-	-
28	120 kN	-	-	M1	M1	M2	M4	M6	M7	M8	-	-	-	-	-	-
30	140 kN	-	-	-	M1	M1	M3	M5	M6	M7	-	-	-	-	-	-
32	160 kN	-	-	-	-	-	M2	M4	M5	M7	M7	M8	-	-	-	-
34	180 kN	-	-	-	-	-	M2	M4	M5	M6	M7	M7	M8	-	-	-
36	205 kN	-	-	-	-	-	M1	M3	M4	M5	M6	M7	M7	M8	-	-
38	225 kN	-	-	-	-	-	-	M4	M5	M6	M6	M7	M8	-	-	-
40	250 kN	-	-	-	-	-	-	M3	M5	M5	M6	M7	M7	-	-	-
42	270 kN	-	-	-	-	-	-	M3	M4	M5	M6	M7	M7	-	-	-
44	300 kN	-	-	-	-	-	-	M3	M4	M4	M5	M6	M7	-	-	-
46	330 kN	-	-	-	-	-	-	M2	M4	M4	M5	M5	M6	-	-	-
48	360 kN	-	-	-	-	-	-	-	M4	M4	M5	M5	M6	M8	-	-
50	390 kN	-	-	-	-	-	-	-	-	M4	M4	M5	M5	M8	-	-
52	420 kN	-	-	-	-	-	-	-	-	-	M4	M4	M5	M8	-	-
54	450 kN	-	-	-	-	-	-	-	-	-	M4	M4	M5	M7	M8	-
56	480 kN	-	-	-	-	-	-	-	-	-	-	M4	M4	M7	M8	-
58	510 kN	-	-	-	-	-	-	-	-	-	-	M4	M4	M7	M8	-
60	530 kN	-	-	-	-	-	-	-	-	-	-	M4	M4	M7	M8	-

* MAX. TENSION IS BASED ON MAXIMUM ROPE STATIC TENSION

STANDARD SHEAVE DIMENSIONAL CHART

SHEAVE	ASSEMBLY	BEARING	DYNAMIC	RD	OD	ØA	C	D	E	F	G	H	L	N	Ød	S	T	W
ASSEMBLY	MASS	SIZE	RATING	mm	mm	mm	mm	mm	mm	mm	mm	mm	mm	mm	mm	mm	mm	mm
TSH200/-/F	23 kg	5007	63 kN	200	255	35	-	150	130	45	54	175	230	4	23	10	16	190
TSH250/-/F	30 kg	5008	80 kN	250	320	40	-	180	150	55	64	215	280	4	23	10	16	220
TSH315/-/F	53 kg	5009	97 kN	315	395	45	-	230	160	62	76	270	330	4	27	12	16	240
TSH350/-/F	87 kg	5014	175 kN	350	440	70	-	360	220	64	73	315	450	4	33	12	16	300
TSH400/-/F	88 kg	5014	175 kN	400	470	70	-	360	220	64	73	315	450	4	33	12	16	300
TSH500/-/F	164 kg	5017	219 kN	500	610	85	-	440	240	78	86	390	570	4	33	16	20	320
TSH630/-/F	246 kg	5018	305 kN	630	730	90	135	380	280	78	86	455	760	8	33	16	25	360
TSH710/-/F	330 kg	5024	410 kN	710	800	120	135	460	320	94	96.5	495	840	8	33	16	25	400
TSH800/-/F	440 kg	5026	540 kN	800	920	130	155	490	340	108	111	540	930	8	33	16	25	420
TSH864/-/F	590 kg	5028	610 kN	864	984	140	170	570	380	108	128	532	1030	8	39	20	20	460
TSH900/-/F	590 kg	5028	610 kN	900	1020	140	170	570	380	108	111	590	1030	8	39	20	28	460
TSH1000/-/F	770 kg	5028	610 kN	1000	1120	140	280	560	290	100	137	716	1250	10 *	39	25	50	400
TSH1102/-/F	960 kg	5028	610 kN	1102	1240	140	280	560	290	100	137	716	1250	10 *	39	25	50	400
TSH1500/-/F	1160 kg	5036	1170 kN	1500	1650	180	375	750	400	110	160	935	1660	10 *	42	36	60	530
TSH1900/-/F	1460 kg	5040	1450 kN	1900	2100	200	375	1150	460	120	174	1180	2110	10 *	52	40	70	620

* FOR LARGER ASSEMBLIES TWO EXTRA MOUNTING HOLES ARE REQUIRED ON MIDDLE OF MOUNTING PLATE ON 'E' CENTERS

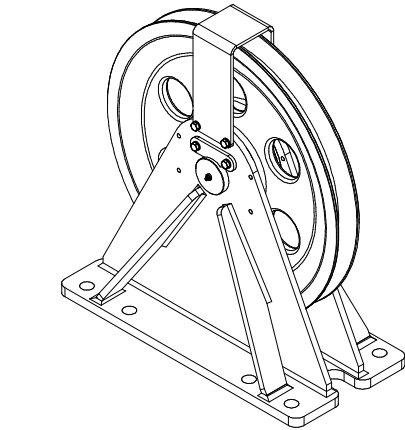

HOW TO ORDER

TEFCO ENGINEERING STANDARD WIRE ROPE SHEAVE ABOVE ARE PER THE STANDARD SHEAVE DIMENSIONAL CHART. HOWEVER CUSTOM DESIGNED SHEAVE ASSEMBLIES CAN BE CREATED FOR NON STANDARD, AND LARGER SIZES. DUAL AND TRIPLE SHEAVE ASSEMBLIES ARE ALSO AVAILABLE.

COMPLETE THE FOLLOWING THREE STEP PROCESS

- CHECK THE APPLICATION AGAINST THE CLASS OF MECHANISMS (AS1418) TABLE.
- CREATE PART NUMBER
 TSH200 - 10 - F
 └───┬─── SUPPLY WITH FRAME (SEE NOTE 4 "FRAME TYPES")
 └───┬─── ROPE DIAMETER
 └───┬─── SHEAVE ROOT DIAMETER
- CONTACT TEFCO ENGINEERING SALES (+612 4325 4433) FOR PRICE AND DELIVERY.
- FRAME TYPES:
 (F) SINGLE SHEAVE FRAME
 (DF) DUAL SHEAVE FRAME
 (TF) TRIPLE SHEAVE FRAME
 (S) SHEAVE ONLY NO FRAME

TECHNICAL DATA

- BEARINGS** NFF OR SL04 SERIES DOUBLE ROW CYLINDRICAL ROLLER BEARINGS ARE USED IN THE STANDARD RANGE FOR SPECIAL APPLICATIONS, ALTERNATIVE BEARINGS ARRANGEMENTS CAN BE OFFERED.
 - PRIME COAT: 50µm DFT INTERCURE 200 ZINC PHOSPHATE.
 - FINISH COAT: 100µm DFT INTERSEAL 670HS (MIO) COLOUR AS2700 Y14 SAFETY YELLOW.
- SURFACE FINISH**
- ROPE GUARD** PREVENTS SLACK ROPES FROM LEAVING THE SHEAVE. ONE ROPE GUARD IS SUPPLIED AS STANDARD WITH EACH FRAME, AND CAN BE MOUNTED IN 3 POSITIONS USUALLY WHERE THE ROPE LEAVES THE SHEAVE.
- LUBRICATION** LUBRICANT IS FUCHS EP2 OR EQUIVALENT APPLIED THROUGH A 1/4" BSP GREASE NIPPLE ON THE SHEAVE AXLE AS SHOWN.
- QUALITY** TEFCO ENGINEERING OPERATES A QUALITY SYSTEM TO ISO9001. CERTIFICATION OF MATERIAL AND TESTING SUCH AS MAGNETIC PARTICLE AND ULTRASONIC IS AVAILABLE AT EXTRA COST ON REQUEST.
- SHEAVE MATERIAL** AS1831/400-15 SG IRON IS STANDARD. FOR HIGHER STRENGTH OR MORE WEAR RESISTANCE THEN VARIOUS GRADES OF CAST STEEL TO AS2074/LC6 ARE AVAILABLE WITH HEAT TREATMENT AS REQUIRED. FOR ALL OPTIONS CONSULT TEFCO WITH DETAILS
- FRAME MATERIAL** MANUFACTURED FROM GRADE AS3678/250 STEEL. FOR HIGH STRENGTH APPLICATIONS AS3678/350 GRADE STEEL MAY BE USED. MANUFACTURED FROM GRADE 316 STAINLESS STEEL ROUND BAR.
- SHAFT MATERIAL**
- WELDING** ALL FRAME WELDING IS TO AS1554.1 SP
- FINITE ELEMENT ANALYSIS** FEA IS AVAILABLE FOR HIGH STRENGTH APPLICATIONS.
- HIGH LOAD APPLICATIONS** ALTERNATIVE FRAME AND SHEAVE DESIGNS ARE AVAILALBE FOR HIGHER ROPE LOADS - CONSULT TEFCO WITH DETAILS
- FRAME MOUNTING** INSTALLATION OF SHEAVE ASSEMBLIES IS OPTIMAL WITH THE BASE PLATE IN COMPRESSION. FOR OTHER MOUNTING OPTIONS CONSULT TEFCO WITH DETAILS

TEFCO ENGINEERING
 3 GIBBENS ROAD, WEST GOSFORD, NSW, 2250
 TEL: +612 4325 4433, FAX: +612 4325 4622
COPYRIGHT: THIS DRAWING IS TEFCO ENGINEERING PROPERTY AND SHALL NOT BE PUBLISHED, REPRODUCED OR GIVEN TO ANY OTHER PARTY WITHOUT WRITTEN PERMISSION

STANDARD WIRE ROPE SHEAVE TABLE DRAWING

DRAWN BY IKT	APPROVED BY	DRAWING NUMBER 900-001	
DATE 22/10/2009	DATE	DATE	DATE

A1 - 840x594 (7)